

SIEVERT® | TW 5000



HOT-AIR AUTOMATIC WELDING MACHINE
299001 400 V ~ / 299047 220-230 V ~

GB	OPERATORS MANUAL	2-13
S	BRUKSANVISNING	14-25
F	MODE D'EMPLOI	26-37
NL	GEBRUIKSAANWIJZING	38-49
D	BEDIENUNGSANLEITUNG	50-61

**SAFETY**

PLEASE READ OPERATORS MANUAL CAREFULLY BEFORE USE AND KEEP FOR FURTHER REFERENCE.

WARNING! To reduce the risk of electric shock, do not expose this product to rain or moisture. Store indoors. Read operators manual before using. When servicing use only Sievert identical replacement parts.

WARNING

- **DANGER!** Always unplug any electronic tool before opening it as live components and connections are exposed.
- Improper use of the TW 5000 hot-air welding machine could cause fire and/or an explosion hazard.
- Never operate electronic equipment near combustible materials and/or explosive gases.
- Touching the element housing and/or nozzle during or after operation could cause burns.
- **CAUTION!** Element housing and/or nozzle have hot surfaces.
- Allow the hot-air welding machine to cool down.
- Do not point the hot-air flow at people or animals.

CAUTION

- The voltage rating stated on the hot-air welding machine should correspond to the mains voltage.
- For personal protection, we strongly recommend the TW 5000 hot-air welding machine be connected to an RCCB (Residual Current Circuit Breaker) before using it on any type of application.
- The TW 5000 hot-air welding machine must be operated under strict supervision.
- The heat can ignite flammable materials which are not in view.
- Protect the TW 5000 hot-air welding machine from any and all standing water, rain and dampness.

TABLE OF CONTENTS

SAFETY.....	2	TROUBLESHOOTING GUIDE.....	10
PRODUCT DESCRIPTION.....	3-4	SERVICE AND REPAIR.....	10
ASSEMBLY.....	5	ACCESSORIES & SPARE PARTS.....	11
OPERATION.....	6-8	TW 5000 OVERVIEW.....	12-13
MAINTENANCE.....	8-9		

PRODUCT DESCRIPTION

PRODUCT DESCRIPTION

Sievert TW 5000 is an electrical hot-air automatic overlap welding machine, specially designed for handling all types of single-ply roofing membranes such as thermoplastic, rubber and modified bitumen (CSPE, ECB, EPDM, PVC, TPO, SBS, APP).

The machine is equipped with a standard nozzle for welding seams up to 50mm width. As an option a separate nozzle is available for handling wider welding seams. The high power fan and heating element ensure high quality welding at maximum speed.

The Sievert TW 5000 has a unique four-wheel drive system, which assures wrinkle free welding for thin roofing membranes. In addition to this, the front wheels are adjustable to allow easy operation at different angles. The powerful motor and efficient drive system allow climbing ability up to 30°.



FEATURES

- Adjustable handle made of sturdy steel.
- Separate free rolling wheels for easy transport.
- Adjustable front wheels to avoid sliding when welding at different angles.
- Belt and wheels made of silicon rubber.
- Four wheel drive system.
- Specially designed nozzle and heat protection cover in stainless steel.
- Independent suspension pressure roller.
- Powerful drive system.
- Equipped with two lifting handles.
- Removable additional weights.
- Built-in temperature sensor.
- Digital LED display showing temperature, speed and operating status.
- Display lamps indicate operation status of the machine.
- Fully adjustable speed, temperature and fan.
- Automatic start/stop sensor when hot-air tool is engaged/disengaged in the drive position.
- All electronics are made in accordance to highest industrial standard.
- All electronics are sealed with high degree coating for maximum humidity protection.

PRODUCT DESCRIPTION

TECHNICAL SPECIFICATIONS

Type no.	299001	299047
Voltage	400 V ~ ± 10%	220 / 230 V ~ ± 10%
Cable Connection	400 V L1-L2	220 V L1-L2 / 230 V N-L1
Power Consumption	6300 W	5000 W
Frequency	50 Hz	60 Hz / 50 Hz
Temperature, fully adjustable	40°C – 650 °C / 100°F - 1200°F	40°C – 650 °C / 100°F - 1200°F
Drive, fully adjustable	0 – 7 m/min / 0 – 20 ft/min	0 – 7 m/min / 0 – 20 ft/min
Air flow, fully adjustable	0 - 48 l/s / 0 – 12.7 gal/s	0 - 48 l/s / 0 – 12.7 gal/s
Emission level	70 dB	70 dB
Nozzle	40 mm / 1.58"	40 mm / 1.58"
Width of welding seam	40 – 50 cm / 1.5" – 2"	40 – 50 cm / 1.5" - 2"
Dimensions	56x38x25 cm / 22"x15"x10"	56x38x25 cm / 22"x15"x10"
Weight (4 kg / 8.8 lb built-in weight)	30 kg / 68 lb	30 kg / 68 lb
Additional weight (included)	8 kg / 17.6 lb	8 kg / 17.6 lb
Additional weight (not included)	4 kg / 8.8 lb (art no 299301)	4 kg / 8.8 lb (art no 299301)
Power cord length	91 cm / 3 ft.	91 cm / 3 ft.

POWER SUPPLY AND EXTENSION CORDS



CAUTION! To provide continued protection against risk of electric shock, connect to properly grounded outlets only.

CAUTION! To reduce the risk of electric shock, keep extension cord connection dry and off the ground.

General information for electric supply

The TW 5000 is delivered with power cord: 3 x 2.5 mm², earth (ground) is green/yellow; the two other wires are neutral and phase 1 at single phase connection and phase 1 and phase 2 at two phase connection.

- Use direct supply from main electric distributor or use a generator.
- Use cables with 3 wires. Please note that the earth (ground) wire is green and yellow.
- Recommended diameter of wires minimum 2,5 mm², maximum cable length 55 metres. If 1,5 mm² wires are used, maximum cable length 35 metres.
- Use only extension cords with sufficient wire diameter in accordance with information above.
- Your country's specifications of electric tools and installations should be respected.

Selecting the right generator

To make sure you choose the right generator, go through these steps:

- Identify the items you want to run.
- Calculate the total surge watts required for all items.
- Select a generator that exceeds your total surge watts.

The multiplying factor between rated and surged watts for TW 5000 and TH 1650 is approx. 1.2. For instance if you run one TW 5000 (220 V) and one TH 1650 (120 V) your total surge watts will be 8040 W ((5000+1700)*1.2). Thus in this case we recommend selecting minimum a 10,000 W generator with 50-amp service.

Be sure to verify wattage requirements for starting and running. Start one item at a time beginning with the largest and ending with the smallest.

ASSEMBLY

CABLE CONNECTIONS

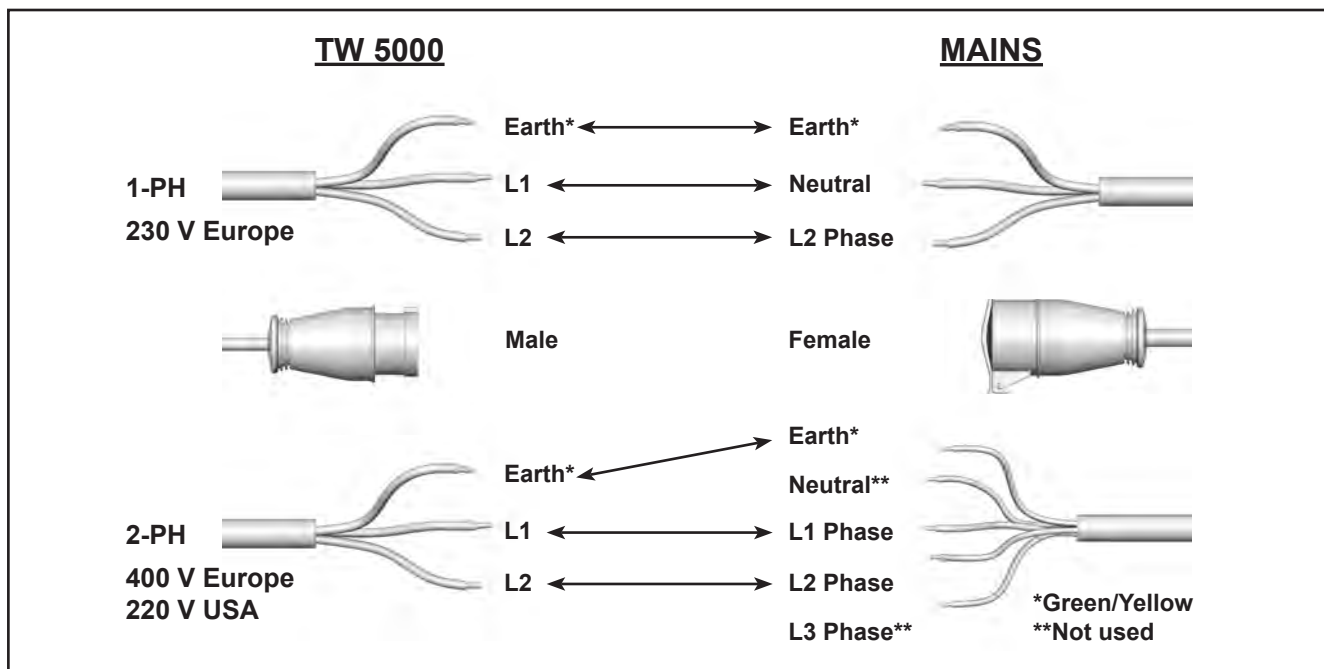

MACHINE ASSEMBLY

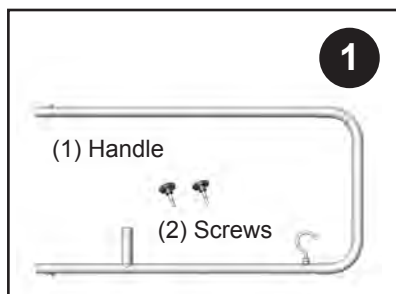

- Unassembled parts.

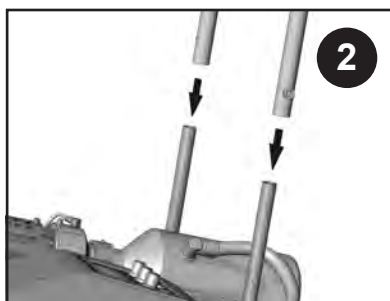

- Attach the handle by sliding it into place over the two receptacles on the machine.



- Adjust the handle to a suitable height for the operator.



- Lock with the two screws provided.



- Attach the mains cable to the cable hook on the handle.
- Connect the machine to the mains.

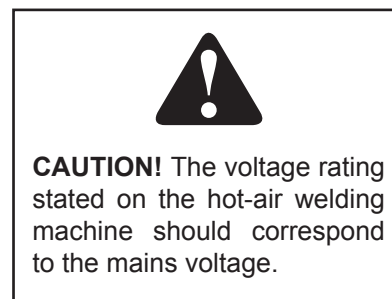

OPERATION

DISPLAY UNIT

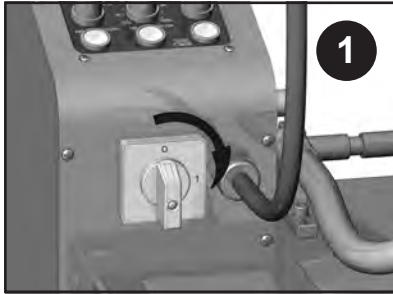

- Turn the power on at the main switch below the control panel. Wait until you see text on the display.



- Select between °C/meter and °F/feet by pushing the button. The machine will remember last used setting.



- Adjust the temperature with the red knob to desirable temperature.

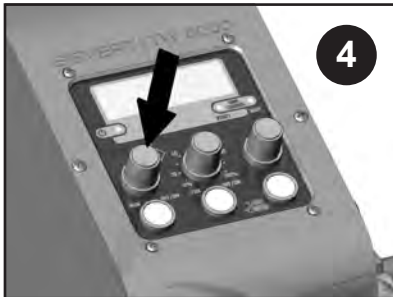

- Adjust the machine speed with the grey knob to desirable speed.



- Adjust the fan speed with the blue knob to desirable speed.



- Push the fan button to start heating up the machine. The red wait indicator will light up.

- 7** It will take a few minutes for the machine to heat up to its programmed temperature. Wait until the red indicator light is switched off and the green ready indicator light comes on. Now the machine is ready to start welding.

PUT THE MACHINE IN CORRECT POSITION

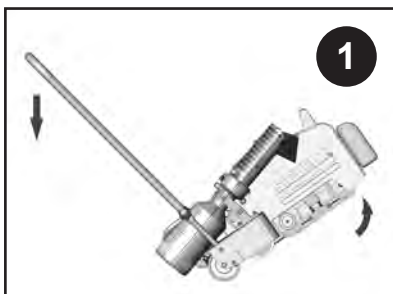

- The machine is equipped with separate transportation wheels for easy transport.
- Tip the machine as shown on picture and easily move it to your desired location.

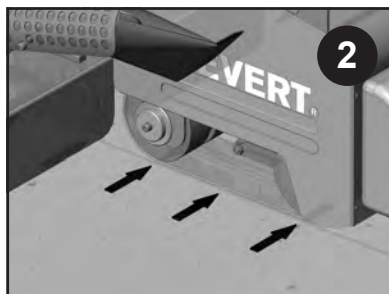

- Align the machine to its correct position with the overlap edge of the membrane.

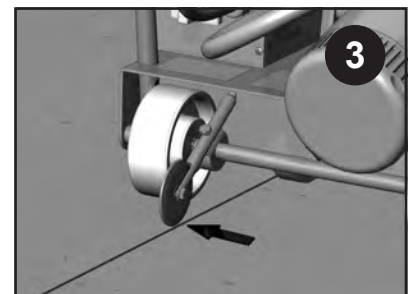

- The adjustable guide wheel and the welding belt should be in line with the edge of the overlapped membrane according to the picture.

OPERATION

START WELDING



IMPORTANT! Always perform sample welds before welding actual production membrane to ensure proper setting of temperature, air flow and speed. See test and control of welding seam.

The machine is equipped with adjustable front wheels to avoid sliding when welding at different angles. The front wheels are preset in the factory for welding in a horizontal position.

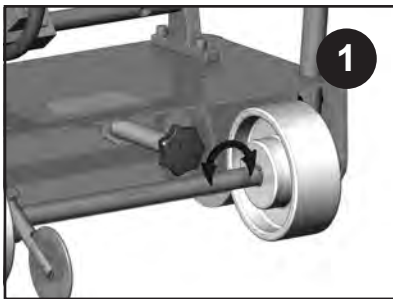

- If you are welding at an angle, adjust the front wheels by turning the front wheel adjustment knob located at the base of the frame until you achieve proper, straight movement of the machine.

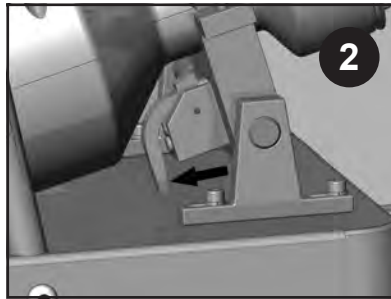

- Release the welding nozzle with the trigger, then lower and guide it to the left underneath the overlapping membrane until it locks. The machine will start automatically when the nozzle is in its locked position. For instruction on how to stop the machine, please see section on “Stopping the machine and cooling down”. If the automatic system is failing, you can start and stop the machine manually with the run button.

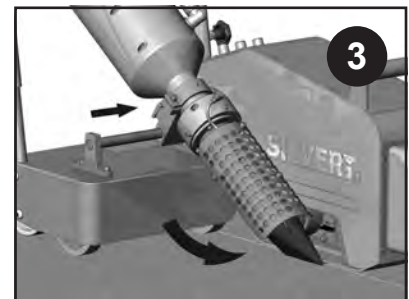

TEST AND CONTROL OF THE WELDING SEAM

Always conduct test welds before you begin any job. Materials will vary between manufacturers therefore the machine settings will vary as well. Always check with the material manufacturer for the proper specifications and machine settings for their material. It should be noted that ambient temperature plays a large part in the machine settings. The warmer it is outside the faster you can run the machine. If you are welding in cold climates, you will have to slow the machine and increase the temperature. Additional weights for the machine are available to add if needed. Start your test weld without the weights and add them accordingly until you achieve an optimum weld.

Set the machine's temperature, speed, and weight according to the manufacturer's specifications and environmental/ambient conditions. Run test welds

and take samples before production welding. Test the welds to ensure that the tests are within manufacturer specifications. Save the test samples for proof that you conducted test welds before you started the job. Test welds should be done again if the environmental/ambient conditions change during the day.

By means of visual inspection you can check the quality of the welds. The material must be welded all the way to the edge of the overlap. This can be checked with a probe tool, similar to an awl. Run the probe along the seam to test the integrity of your welds. With PVC you will find a bead of PVC that has formed along the seam, called bleed through. This is acceptable and indicates a proper weld, as long as it is not darkened or shows any burning. With TPO materials you will not see this bead.

OPERATION

STOPPING THE MACHINE AND COOLING DOWN

After you have finished welding, press the release trigger positioned under the nozzle and guide the nozzle all the way to the right. The drive will immediately stop when you move the nozzle to the right. Set the nozzle in a position pointing upwards.

To activate the cooling down sequence simply push the fan button and wait. Text "Cooling!" will appear in the display window. The heat is turned off immediately but the fan will continue to run and will stop automatically after the temperature has dropped to a sufficient cool down level.



CAUTION! Hot surface; avoid contact. This cooling process is necessary to avoid damage to the heating element.

Wait until the cooling process is finished before you turn off the power at the main switch.

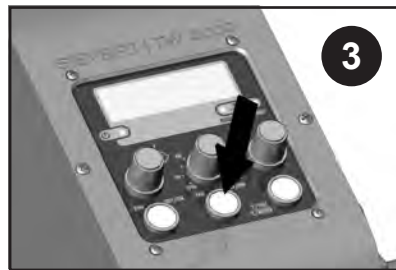
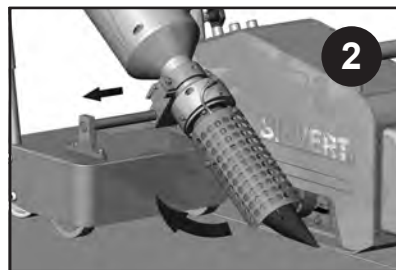
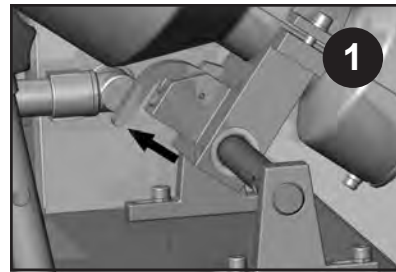

MAINTENANCE

CHANGING THE HEATING ELEMENT



WARNING! To reduce the risk of fire or electric shock, make sure that the TW 5000 hot-air welding machine is disconnected from the supply circuit before changing the heating element.

- Stop the machine as described and remove the plug from designated power source.



WARNING! Touching the element housing and/or nozzle during or after operation could cause burns.

CAUTION! Element housing and/or nozzle have hot surfaces. Allow the hot-air welding machine to cool down before you exchange the heating element.

MAINTENANCE

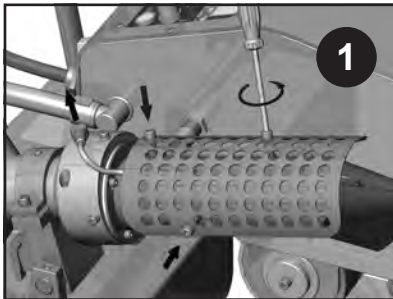

- Unscrew the three screws and remove the heat shield on nozzle and unplug the sensor carefully.

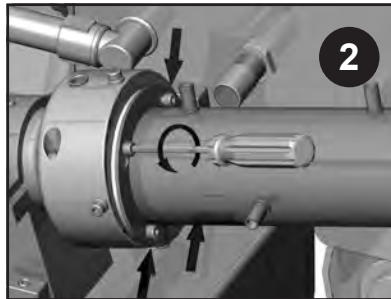

- Release the four screws on the nozzle flange.

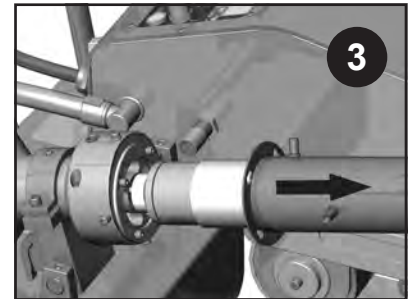

- Take off the nozzle by turning it clockwise and pulling it away from the fan housing.

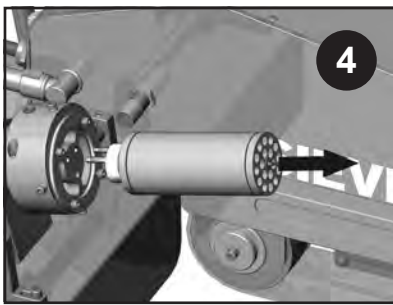

- Remove used heating element by pulling it away from its connection. Insert new heating element for 230 V or 400 V respectively.

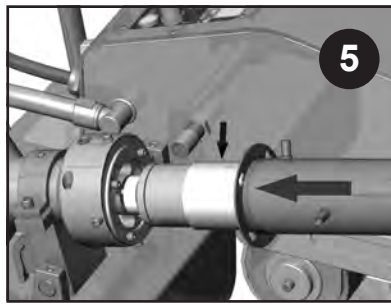

- Important! Replace the tube for the heating element, to prevent air passing in between the nozzle and the element.

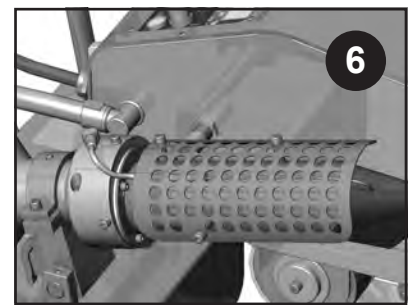

- Replace the nozzle and turn it until screws are locked. Tighten the screws.
- Plug in the sensor and replace the heat shield on nozzle.

CLEANING

- Do not clean the TW 5000 hot-air welding machine with a water spray or similar.
- Clean the welding nozzle with a brass wire brush.
- For optimum machine performance keep the silicone wheels and belt clean from dirt.
- Annual maintenance shall be carried out by an authorized service centre.



WARNING! Touching the element housing and/or nozzle during or after operation could cause burns.

STORAGE AND TRANSPORT

- Store product indoors when not in use – out of the reach of children.
- Always transport and store the TW 5000 in the provided steel box, to prevent the machine from being damaged or exposed to improper weather conditions.

TROUBLESHOOTING GUIDE

PROBLEM	CAUSE	CORRECTION
Will not start	1. No Power	1. Check the electric supply or the fuses
The desired temperature is not reached	1. The temperature is set to 0°C/0°F 2. Wrong heating element is used 3. Tube for heating element missing 4. Defective heating element	1. Set correct temperature 2. Change heating element 3. Replace tube 4. Insert a new heating element
The machine is not mowing	1. Defective cog belt 2. Defective drive engine	1. Replace cog belt 2. Contact service centre
The machine is not functioning. Fan running, text on display: "TEMPSENSOR FAILURE"	1. The temperature sensor is not plugged in properly 2. Faulty temperature sensor	1. Plug in temperature sensor correctly 2. Replace temperature sensor
The machine is not functioning. Text on display: "INPUT VOLTAGE < 180V"	1. Too low incoming voltage	1. Check power supply
The machine is not functioning. Text on display: "INPUT VOLTAGE > 450V"	1. Too high incoming voltage	1. Check power supply
The machine is not functioning. Fan running, text on display: "HIGH AMBIENT TEMPERATURE"	1. Fan unit overheated	1. Make sure that the air intake is clean and not clogged

SERVICE AND REPAIR

All service and repair should be done only by an authorized Sievert Service Centre.

For a service centre near you, please see contact information on the backside or at www.sievert.se

ACCESSORIES & SPARE PARTS

Only official and approved Sievert accessories and spare parts shall be used.

ACCESSORIES



Art no. 299301
Additional weight 4 kg



Art no. 799070
Metal transport box



Art no. 799080
Cleaning brush with
brass wire



Art no. 799001
Replacement heating
element 400 V ~



Art no. 799047
Replacement heating
element 230 V ~

SPARE PARTS



Art no. 799010
Welding belt

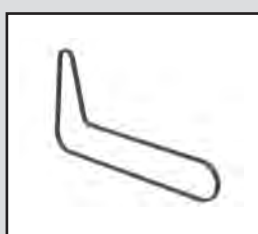

Art no. 799020
Drive belt



Art no. 799030
Nozzle 40 mm



Art no. 799040
Temperature sensor



Art no. 799050
Fan complete



Art no. 799060
Electronic display unit



Art no. 799090
Screw repair kit

TW 5000 OVERVIEW

- | | | |
|----------------------------|----------------------------|------------------------------|
| 1 Cable hook | 7 Weight 8 kg / 17.6 lb | 13 Automatic start indicator |
| 2 Handle adjustment knob | 8 Pressure wheel | 14 Drive indicator |
| 3 Nozzle heat shield | 9 Silicone welding belt | 15 Status "wait" indicator |
| 4 Welding nozzle | 10 Adjustable front wheels | 16 Status "ready" indicator |
| 5 Tube for heating element | 11 Fan release trigger | 17 Temp. adjustment knob |
| 6 Heating element | 12 Adjustable handle | 18 °C/m or °F/f |

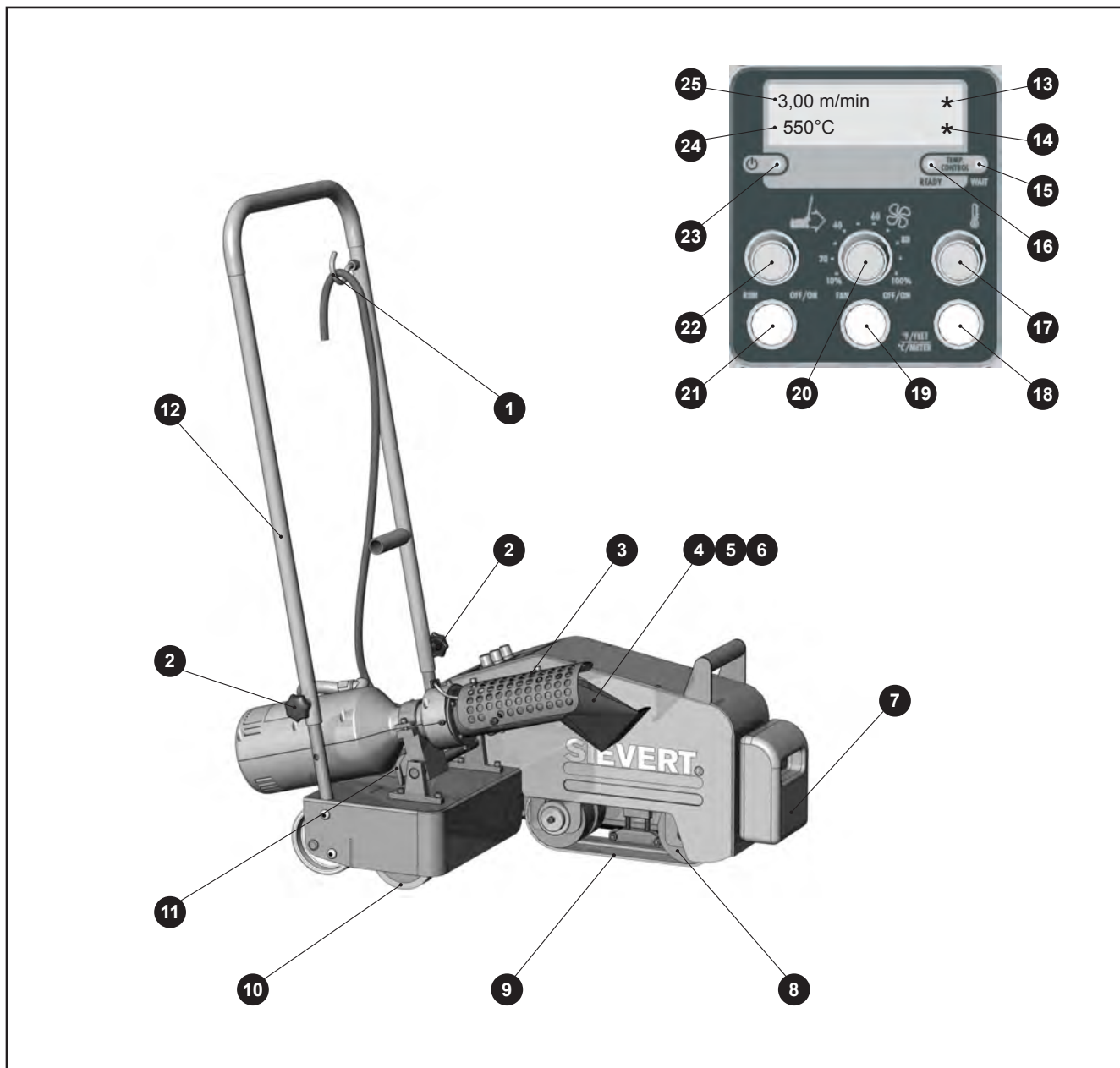

TW 5000 OVERVIEW

- | | | |
|--------------------------|--------------------|---------------------------------|
| 19 Start button | 25 Speed indicator | 31 Transportation wheel |
| 20 Fan adjustment knob | 26 Lifting handle | 32 Front wheels adjustment knob |
| 21 Manually run button | 27 Display unit | 33 Guide wheel adjustment bolt |
| 22 Speed adjustment knob | 28 Lifting handle | 34 Guide wheel |
| 23 Power indicator | 29 Power cord | 35 Main switch on/off |
| 24 Temperature indicator | 30 Fan unit | |

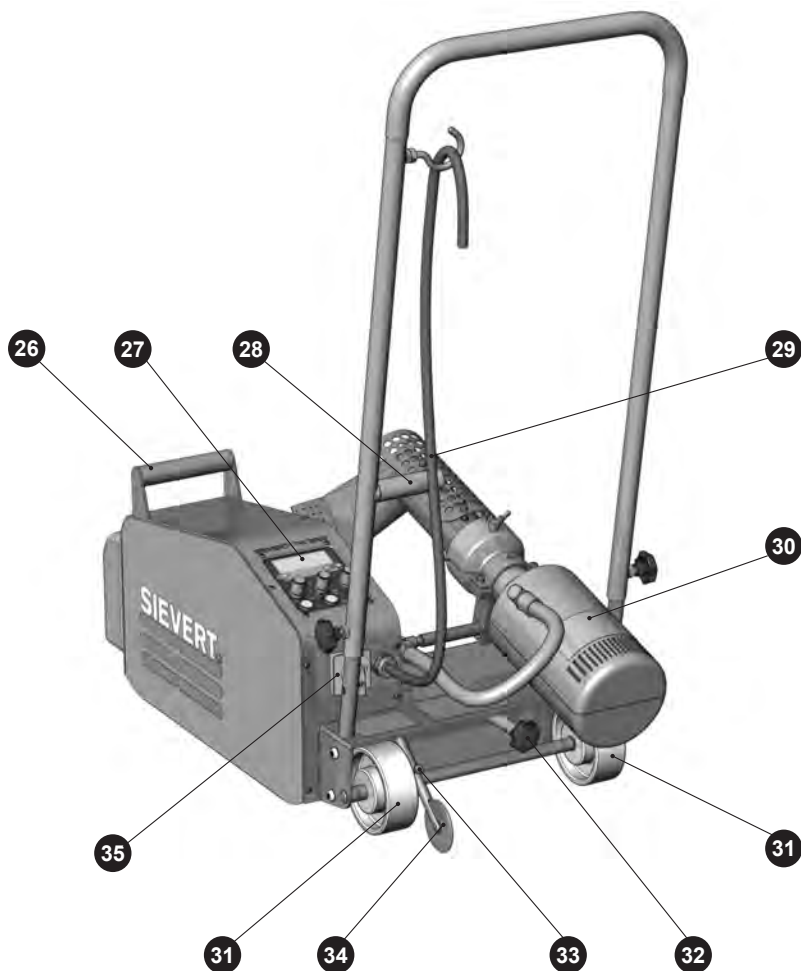

US

Sievert Industries, Inc.
5255 Zenith Parkway
Loves Park, IL 61111
Ph: +1 815 639 1319

S

Sievert AB
P.O Box 1366
SE-171 26 Solna
Ph: +46 8 629 22 00

D

Sievert GmbH
Ettore-Bugattistr. 43
Gewerbepark II
DE-51149 Köln/Porz
Ph: +49 2203 953 10

F

S.A Sievert
Antwerpsesteenweg 59
BE-2630 Aartselaar
Ph: +32 3 870 87 87

NL

B

Sievert N.V
Antwerpsesteenweg 59
BE-2630 Aartselaar
Ph: +32 3 870 87 87

N

Primus AS
Postboks 58, Alnabru
NO-0614 Oslo 6
Ph: +47 23 384 320

DK

Andersen & Nielsen København A/S
H.J Holst Vej 6
DK-2610 Rødovre
Ph: +45 364 102 00

FIN

Oy Primus Ab
PL 116
FIN-02201 Espoo
Ph: +358 9 525 9360

GB

James Lister & Sons Ltd.
Sandwell Industrial Estate
Spon Lane South, Smethwick
West Midlands, B66 1QJ
Ph: +44 121 506 1818

I

Ferrutat Colimar SPA
Viale Monza 338
IT-20128 Milano
Ph: +39 0227 000 607

E

Stag S.A
Poligono Industrial de Vallecas
C/ Luis I, Nave 6-A2
E-280 31 Madrid
Ph: +34 91 777 0866

CH

Intergros Handels AG
Alter Zürichweg 21
CH-8952 Schlieren
Ph: +41 175 577 77

RU

Petroprimus ZAO
Kantimirovkaja UL D.7
RU-194100 St. Petersburg
Ph: +7 812 327 4418

CZ

Patimex Ots
NA Zizkove 523
CZ-364 52 Zlutice
Ph: +420 353 393 642

PL

Rothenberger Polska SP.ZO.O
UL. Cyklamenow 1
PL-04-798 Warszawa
Ph: +48 22 612 77 01

GR

Rothenberger Hellas SA
249 Sigrou Avenue
GR-171 22 N. Smirni
Ph: +30 210 940 7302

SIEVERT®

DESIGN AND QUALITY
SIEVERT AB SWEDEN SINCE 1882
www.sievert.se